

POOL CUE RACK

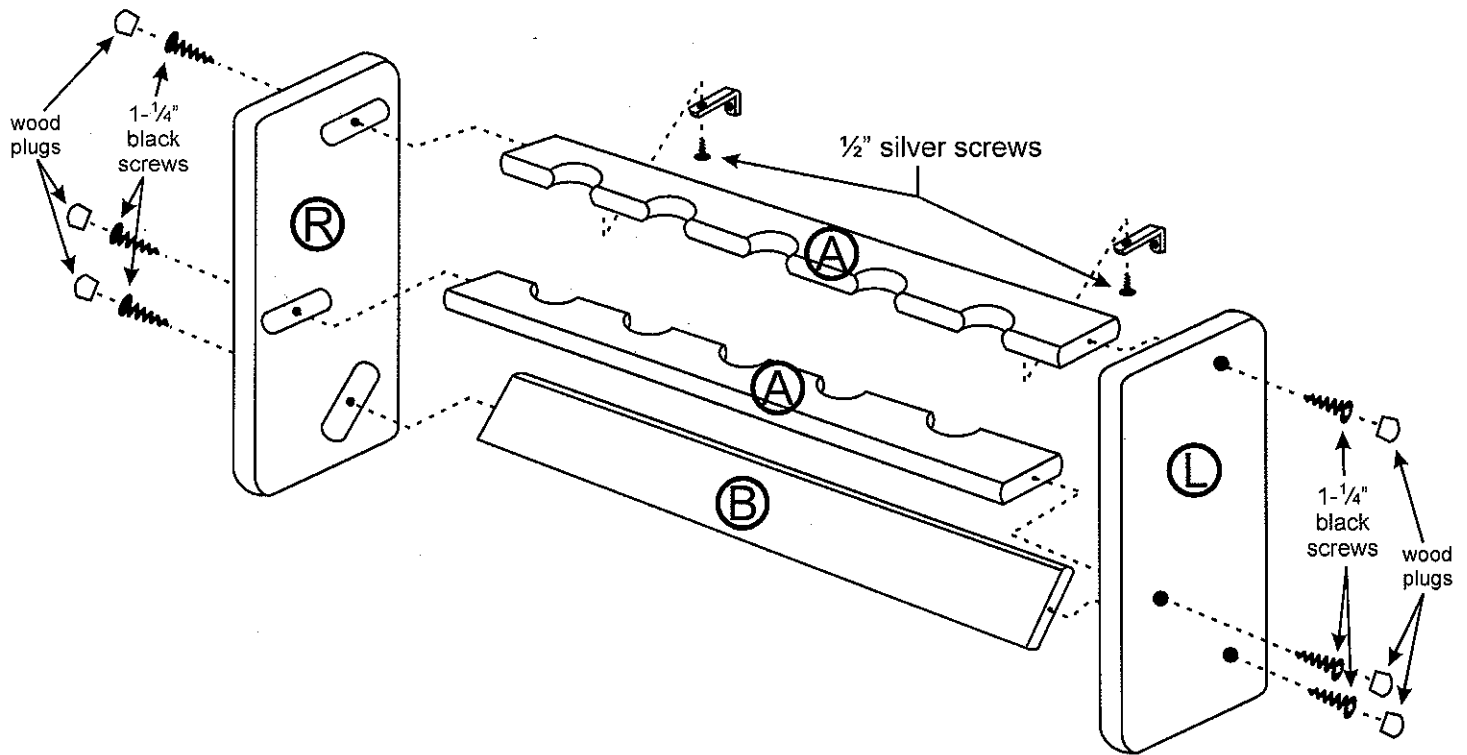

1. Screw the 2 black L-brackets into the predrilled holes on the bottom side of one of the notched rails (A) using the $\frac{1}{2}$ " silver screws . The long side of the L-bracket should be against the wood rail.
2. Screw the wood rail (A) with the L-brackets into the top recessed slot of the side (L) using a 1-1/4" black screw. Be sure that the L-brackets are on the bottom side and the open hole on the L-bracket is facing the back of the rack. These brackets will be used if mounting the rack to a wall.
3. Screw the second notched wood rail (A) in to the center recessed slot of side (L) using a 1-1/4" black screw. The notches of the wood rail should face the back of the rack and the drilled holes should face the bottom of the rack so they won't show.
4. Screw the rail (B) into the 45 degree recessed slot on side (L) using a 1-1/4" black screw.
5. Align all three wood slats into the recessed slots on the other side (R) using the 1-1/4" black screws.
6. Make sure all rails are aligned properly and the L-brackets and small holes in parts (A) are facing down, plug screw holes with wood plugs provided using a small hammer.

This rack can be used as a free standing rack on the floor or mounted to the wall using the provided wall hardware by using the black L-brackets on the rack.

For Questions please call 605-225-5081